



General Certificate of Secondary Education
2019

Centre Number

--	--	--	--	--

Candidate Number

--	--	--	--	--

Physics

Unit 3 Practical Skills

Booklet B



Foundation Tier

[GPY32]

GPY32

TUESDAY 18 JUNE, MORNING

TIME

1 hour.

INSTRUCTIONS TO CANDIDATES

Write your Centre Number and Candidate Number in the spaces provided at the top of this page.

You must answer the questions in the spaces provided.

Do not write outside the boxed area on each page or on blank pages.

Complete in black ink only. **Do not write with a gel pen.**

Answer **all** questions.

INFORMATION FOR CANDIDATES

The total mark for this paper is 70.

Figures in brackets printed down the right-hand side of pages indicate the marks awarded to each question or part question.

Quality of written communication will be assessed in Question **3(a)**.

You should have a ruler and a protractor.



- 1 A student is given a uniform metre rule and some weights. The apparatus is used to investigate moments.



The metre rule is placed on a triangular block of wood (pivot) as shown above.

- (a) Where should the triangular block be placed to balance the metre rule?

Position _____

Explain your answer.

[2]

- (b) State how you calculate the moment of a force.

[1]

- (c) The weights used were in the form of a metal square as shown in the diagram below. Mark with the letter **X** the centre of gravity of the metal square. Show clearly on the diagram how you get your answer.



[2]



(d) Diagrams A and B show two attempts by the student to place a weight on the metre rule at the 20 cm mark.

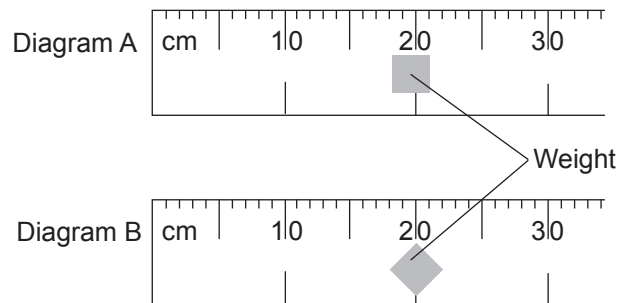

Explain the advantage of placing the weight as shown in Diagram B.

[1]

[Turn over



(e) State in words the Principle of Moments.

[3]

(f) The student carried out the investigation by placing known weights on opposite sides of the pivot.
The weights were adjusted until the metre rule was **balanced**.

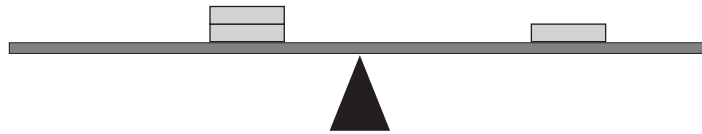

The results of the investigation are shown in the **incomplete** table opposite.

- Use the Principle of Moments to complete the table.
- Include the unit for moment in the column headings.
- Use the space below for calculations.

Calculations



Distance from pivot on the LEFT/cm	Weight/N	Anti-clockwise Moment/ _____	Distance from pivot on the RIGHT/cm	Weight/N	Clockwise Moment/ _____
20	1		20		
10			20	2	
25	4			5	

[6]

- (g) The student placed a 5 N weight 40 cm to the left of the pivot. Explain, with the help of a suitable calculation, why the student was unable to balance the metre rule using a 3 N weight on the right of the pivot.

[2]

[Turn over



- 2 (a) Two mirrors, M_1 and M_2 , are placed at right angles to each other. The diagram shows a ray of light incident on mirror M_1 .

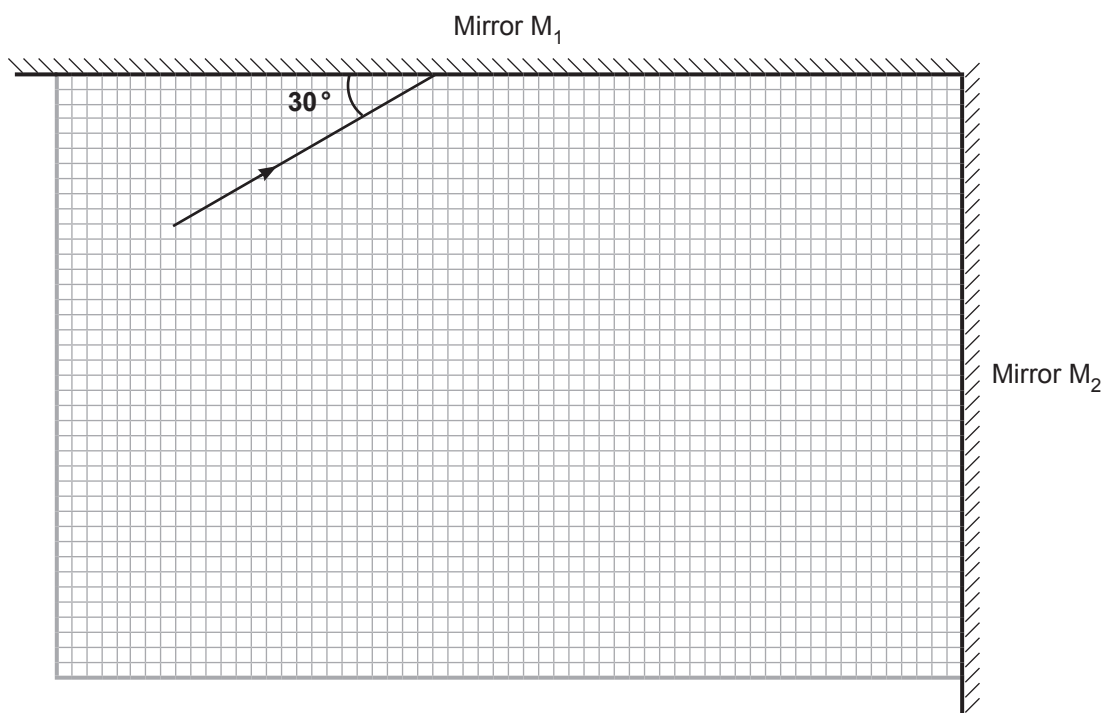

- (i) Using a protractor, carefully draw on the diagram the ray reflected from M_1 .
Label this ray R. [1]
- (ii) Calculate the angle of incidence at mirror M_1 . _____ $^\circ$ [1]
- (iii) State the angle of reflection at mirror M_1 . _____ $^\circ$ [1]
- (iv) What is the size of the angle between mirror M_1 and the reflected ray from M_1 ? _____ $^\circ$ [1]
- (v) Calculate the angle of incidence of ray R at mirror M_2 . _____ $^\circ$ [1]



(vi) Using a protractor, carefully draw on the diagram the ray reflected from M_2 .
Label this ray S. [1]

(vii) Comment on the direction of ray S compared with the direction of the ray incident on M_1 . [1]

(b) Tick (✓) the **three** boxes below which describe the image in a plane mirror.

Inverted

Larger than the object

Laterally inverted

Real

Same size as the object

Virtual

[3]

[Turn over



- (c) The diagram shows a ray of light incident on a triangular glass prism. The light is composed of two colours, red and blue.

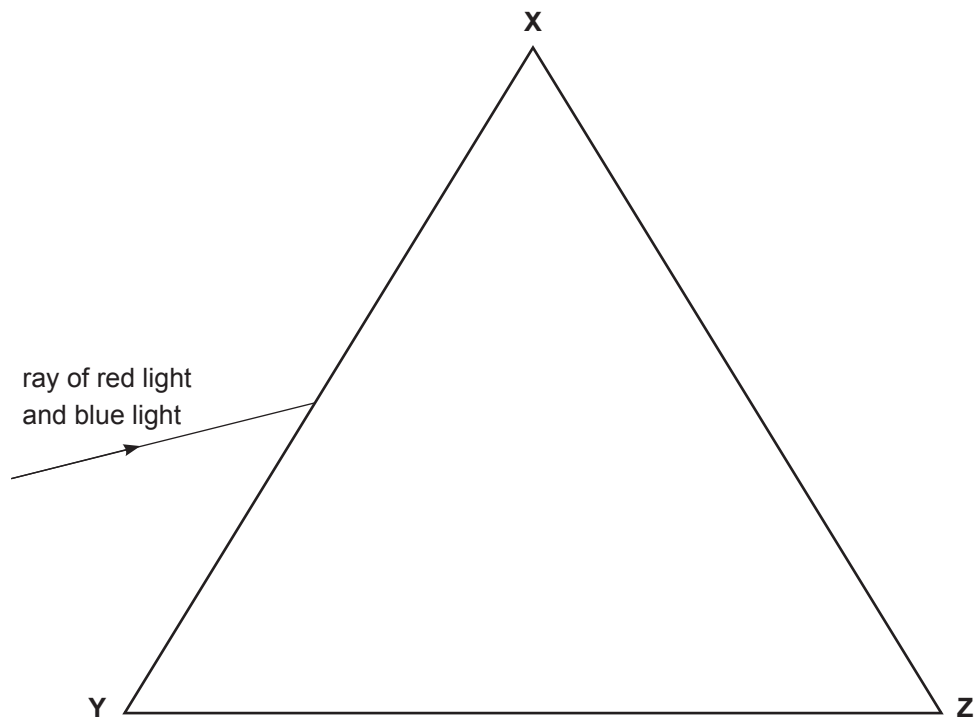

- (i) **With a protractor and a ruler**, draw a normal at the point where the light enters the glass. [1]
- (ii) **Using a ruler**, mark the passage of both colours in the glass, until they both strike the side **XZ**. Label the red ray in the glass **R** and the blue ray **B**. [2]
- (iii) Carefully mark the angle of refraction of the **blue** ray in the glass with the letter **r**. [1]



- (iv) Choose the sentence below which best explains why the red and blue rays of light behave differently when they enter the glass.
Tick (✓) only the correct sentence.

Red light travels at the same speed as blue light in air but red light travels faster than blue light in glass.	
Red light travels at a faster speed than blue light in both air and glass.	
Red light travels slower than blue light in both air and glass.	
Red light travels at the same speed as blue light in air but travels slower than blue light in glass.	

[1]

- (v) Which colour, if any, has the larger angle of incidence **in the glass** at the side **XZ**?
Tick (✓) only the correct sentence.

Both have the same angle of incidence.	
Red light has the larger angle of incidence.	
Blue light has the larger angle of incidence.	

[1]

- (d) When **white light** enters a glass prism it breaks up into many different colours. These colours can be shown on a screen.

- (i) What name is given to these different colours on the screen?

_____ [1]

- (ii) List the colours seen in order of **decreasing** wavelength.

_____ [1]

[Turn over



- 3 (a) The aim of an experiment is to measure the power of a small electric motor. The diagram below shows the apparatus assembled to do this.

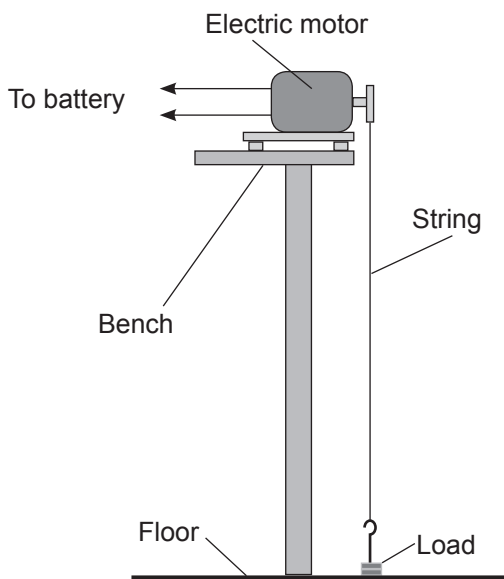

Describe in detail how this experiment should be carried out. In your answer, you should state the following:

- the measurements you would make and the apparatus you would use to make the measurements;
- the measurement which should be repeated and why;
- the calculations needed to determine the power of the motor.

In this question, you will be assessed on your written communication skills including the use of specialist science terms.

Measurements and apparatus _____



Measurement to be repeated and why _____

Calculations _____

_____ [6]

(b) (i) Power is measured in watts (W). Explain what 1 W is.

_____ [2]

(ii) The load moves upwards at a **constant speed**.
Complete the table to show the energy of the **load** as it moves upwards
from the ground. Place a tick (✓) in the appropriate box.

	Decreases	Remains constant	Increases
Kinetic energy			
Potential energy			
Total energy			

[3]

[Turn over



The diagram below represents the energy changes that happen with the electric motor.

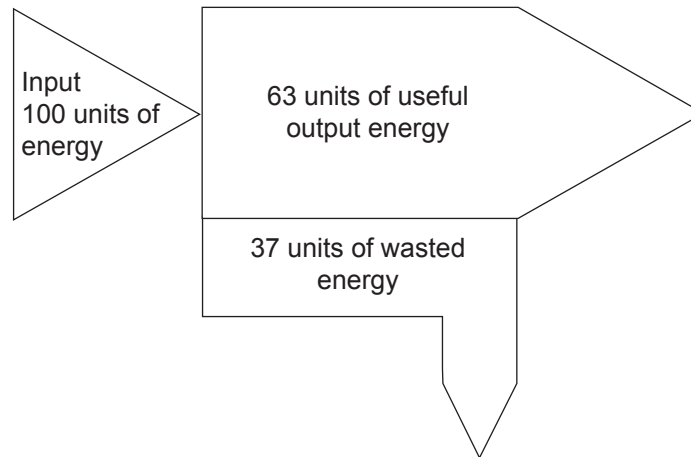

(iii) Name the two types of energy that amount to 37 units of wasted energy.

1. _____ 2. _____ [2]

(iv) Calculate the efficiency of the electric motor using the data from the diagram.

Show clearly how you get your answer, starting with the equation you plan to use.

Efficiency = _____ [3]



- (c) In another experiment, the motor was used to lift different loads. The speed at which the load was lifted was measured for each load. The results are shown in the graph below.

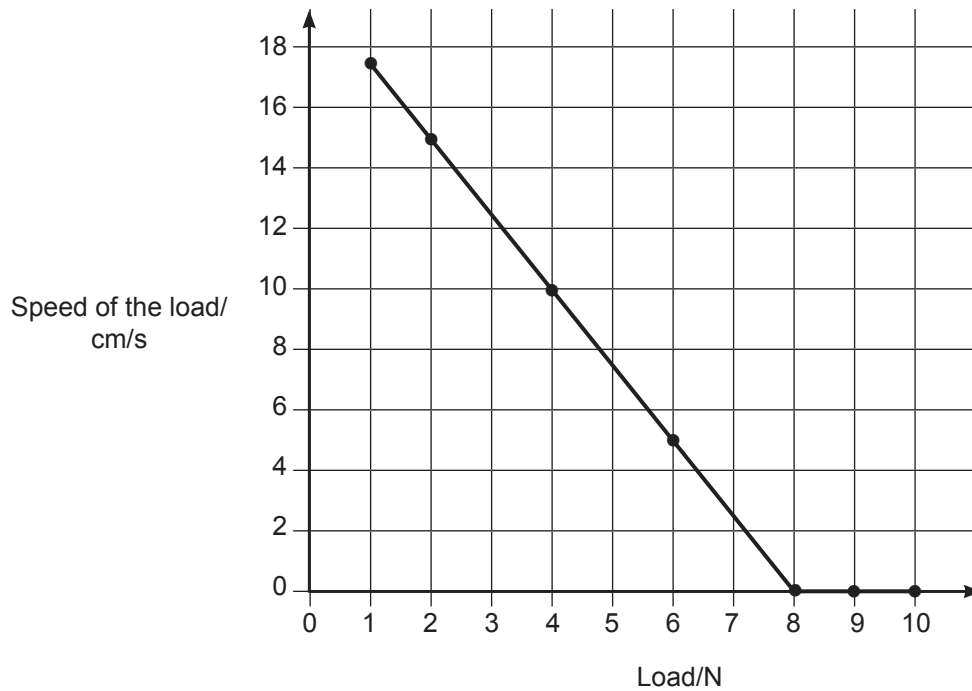

- (i) For loads less than 8 N, what does the graph tell you about the load and the speed?

_____ [1]

- (ii) Describe what the graph tells you about the motor when the load exceeds 8 N.

_____ [1]

[Turn over



BLANK PAGE
DO NOT WRITE ON THIS PAGE

11844



20GPY3214



4 (a) The diagram below shows a coil of wire with a metal core.

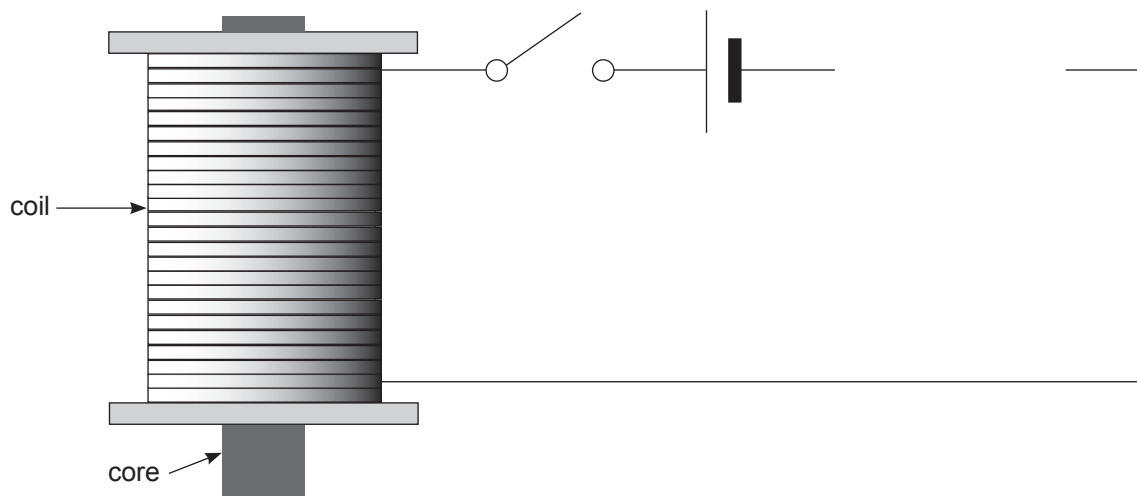

When an electric current flows through the coil the metal core becomes an electromagnet.

(i) From what metal should the core be made?

_____ [1]

(ii) What additional components are needed to vary the current in the coil and measure it? Write your answers in the boxes below.

To vary the current in the coil	
To measure the current in the coil	

[2]

(iii) Complete the circuit above by adding these additional components in the appropriate spaces. **You must use the correct electrical symbols.** [2]

[Turn over



- (b) The electromagnet was used to pick up paper clips as shown in the diagram below.

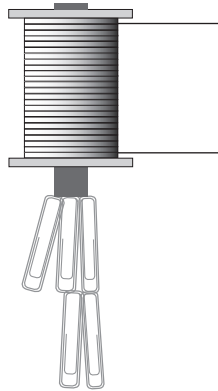

The maximum number of paper clips that the electromagnet could lift was counted for each value of the current.

The results obtained are shown in the table below.

Current/mA	0	50	100	150	200	250
Maximum number of paper clips	0	5	10	15	20	25

Using the grid opposite, you are to plot a graph of maximum number of paper clips against current.

- (i) Choose a suitable scale for the horizontal axis, label it and include the correct unit. [2]
- (ii) Plot the points of maximum number of paper clips against current. [4]
- (iii) **Using a ruler**, draw the straight line of best fit. [1]

The student carrying out this experiment correctly concludes that the maximum number of paper clips is **directly proportional** to the current in the coil.

- (iv) What two features of the graph would lead the student to this conclusion?

1. _____
2. _____ [2]





Maximum number
of paper clips

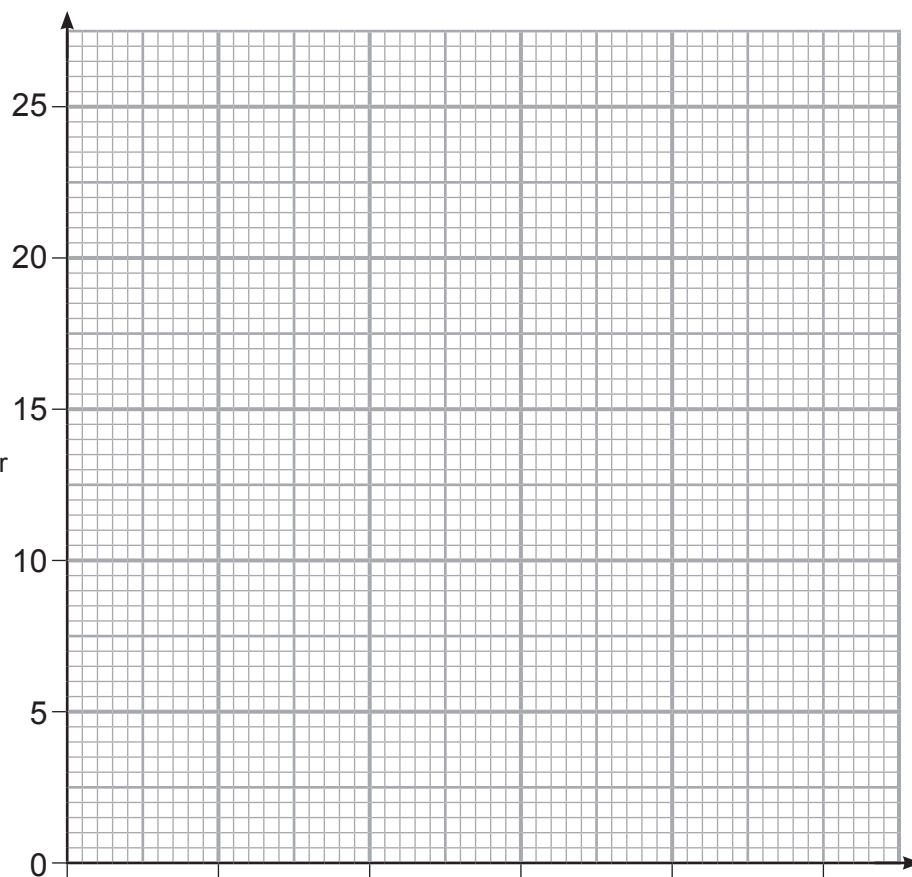

- (v) Use your graph to find the maximum number of paper clips that the magnet would lift when a current of 225 mA is flowing.
Show carefully on your graph how you obtained your answer.

Maximum number of paper clips = _____ [3]



THIS IS THE END OF THE QUESTION PAPER

BLANK PAGE

DO NOT WRITE ON THIS PAGE

11844



20GPY3218





BLANK PAGE
DO NOT WRITE ON THIS PAGE

11844



20GPY3219

DO NOT WRITE ON THIS PAGE

For Examiner's use only	
Question Number	Marks
1	
2	
3	
4	
Total Marks	

Examiner Number

Permission to reproduce all copyright material has been applied for.
In some cases, efforts to contact copyright holders may have been unsuccessful and CCEA will be happy to rectify any omissions of acknowledgement in future if notified.

239088



20GPY3220

